

TECHNICAL DATA

Three Phase Electric Motors - Cast Iron Frame
 PE30 112 M 6 IE3
 2.2 kW / 3 Cv
 970 RPM

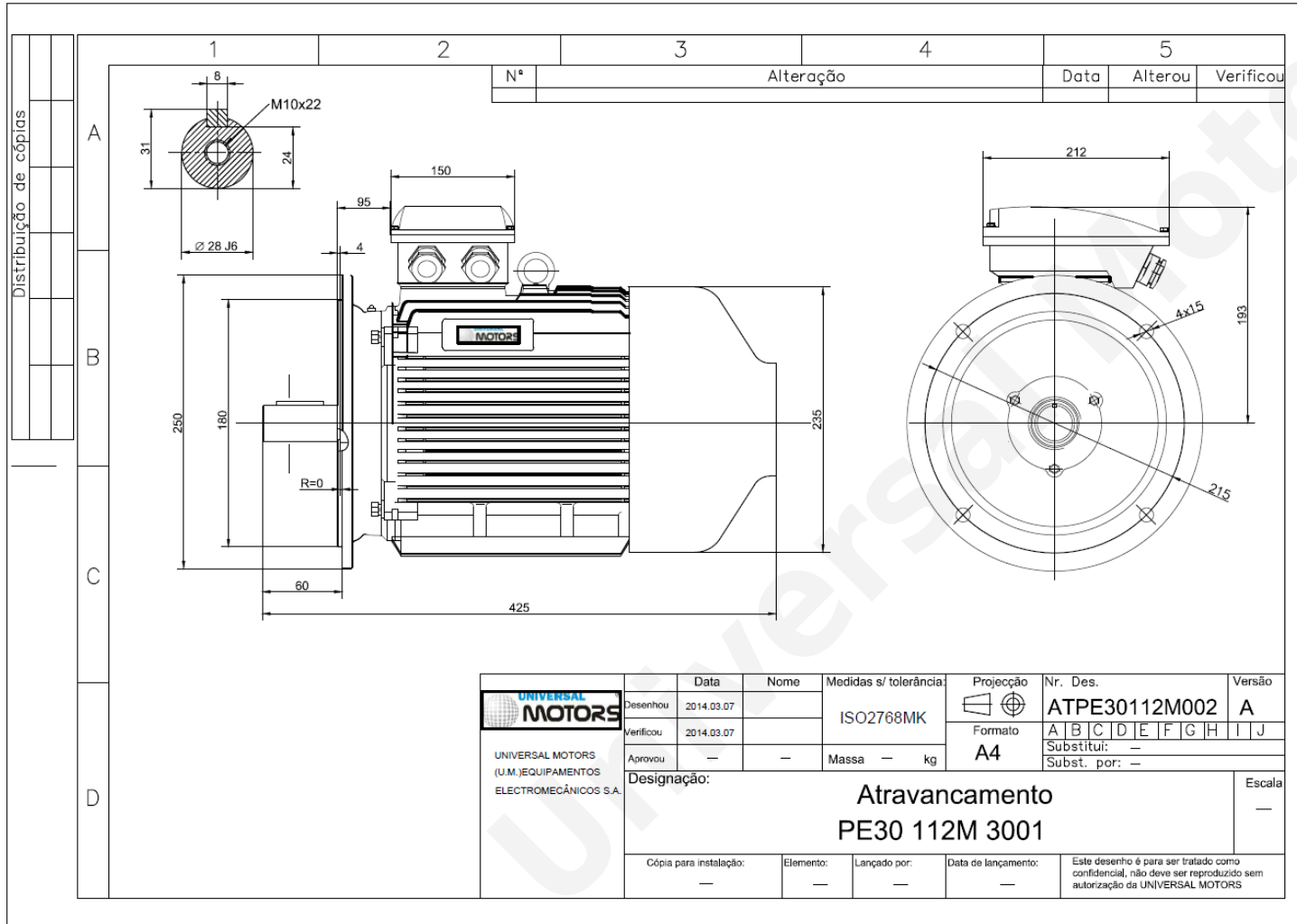

Motor type:	PE30 112 M 6 IE3
Output:	2.2 kW / 3 Cv
Speed (min ⁻¹):	970 RPM
Frequency:	50 Hz
Voltage:	400 V
Current:	5.09 A
Power factor (Cos Ø):	0.74
Poles:	6
Insulation class:	F
Temperature rise Class:	B
Efficiency 50%:	83.0 %
Efficiency 75%:	84.7 %
Efficiency 100%:	84.4 %
Torque:	22 N.m
Tstarting/Tnominal:	2.0
Istarting/Inominal:	6.6
Tmaximum/Tnominal:	2.1
Noise:	54 Db(A)
Weight:	49 Kg
Bearing DE:	6306 2Z C3
Bearing NDE:	6306 2Z C3

Regime - S1

Altitude - 1000m

Environment Temperature - 40°C

CONTACTS:

UNIVERSAL MOTORS Tel: +351 252 299 080
 Rua de São Brás,745 Fax: +351 252 299 089
 4480-782 VILA DO CONDE Mail: geral@universalmotors.pt

* References applied only in the UK